



Driving
TECHNOLOGICAL
EXCELLENCE

INTERFACE VALVE

Hydraulic Interface Valve is a two position, three-way normally closed block and bleed pilot operated hydraulic controller. The device is designed to block the incoming hydraulic supply pressure and bleed the outlet supply pressure in conditions where applied pilot supply pressure is relatively low.

FEATURE

- Sturdy build of a stainless-steel body
- Comprises Viton sealing that endures extremely high pressure and temperatures
- Customized process connections in different sizes as per customer demand
- Compatible with various hydraulic fluids. Reach out to our technical support team to understand fluid suitability in detail

TECHNICAL DATA

- Inlet pressure ranges (Max): Up to 200, 414 & 690 Bar(g)
- Outlet pressure ranges (Max): Up to 200, 414 & 690 Bar(g)
- Maximum pilot pressure: Up to 10 bar(g)
- Configuration: 3-way 2 position

MOC:

1. Body: SS316/SS316L
2. Orifice & spool: SS 17-4 PH
3. Valve nut: Duplex SS
4. Piston: SS316L
5. Seals: FKM (Viton)
6. Other materials on request

Temperature Rating:

- -10°C to 100°C

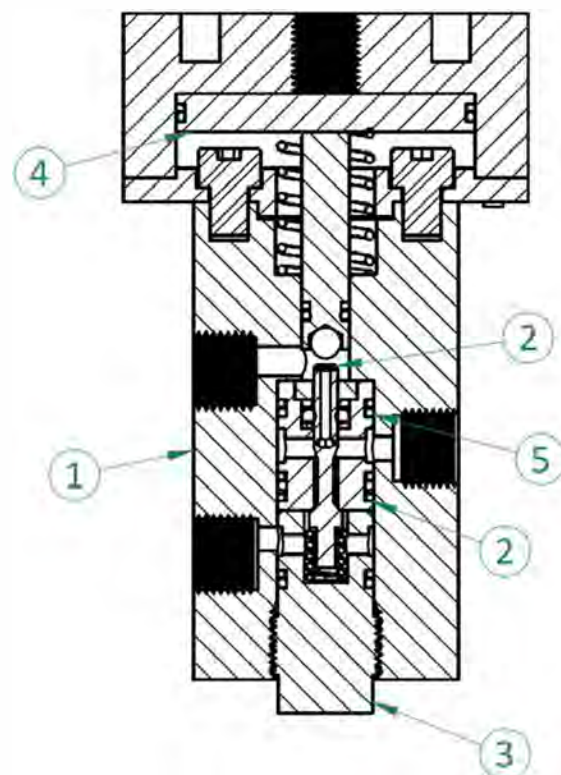

MOUNTING ARRANGEMENT

200Bar

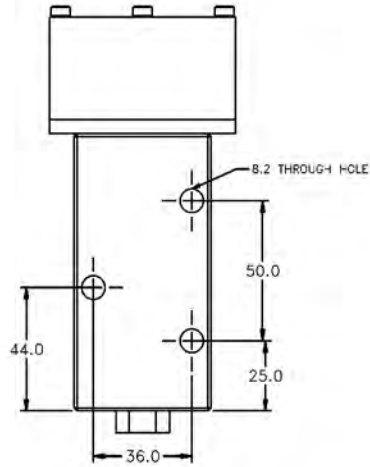

414 & 690 BAR

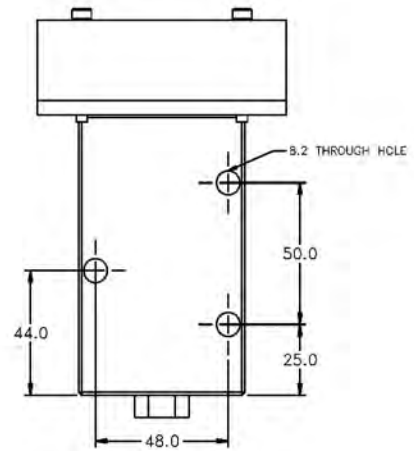

FLOW VS PRESSURE DROP (ALL MODELS)

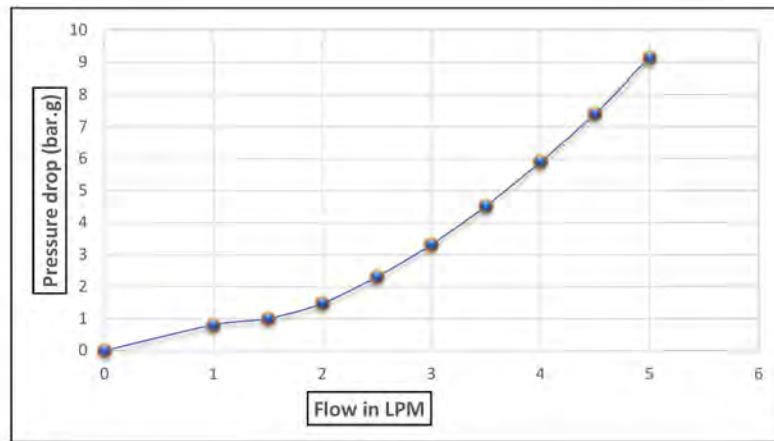

PILOT PRESSURE VS VALVE PRESSURE : (690 BAR)

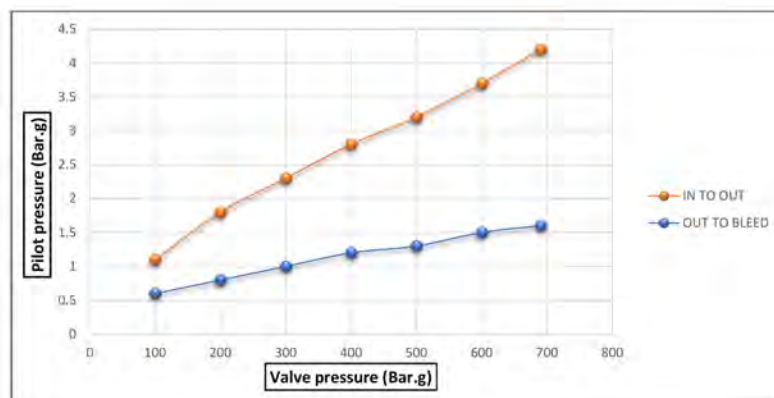

PILOT PRESSURE VS VALVE PRESSURE : (414 BAR)

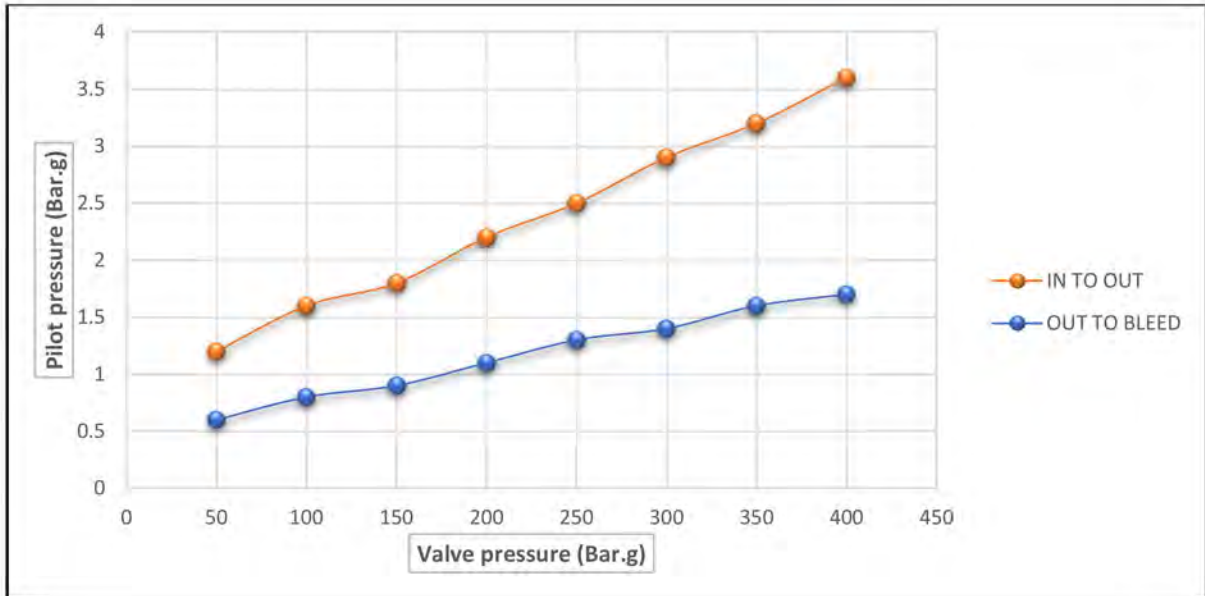

PILOT PRESSURE VS VALVE PRESSURE : (200 BAR)

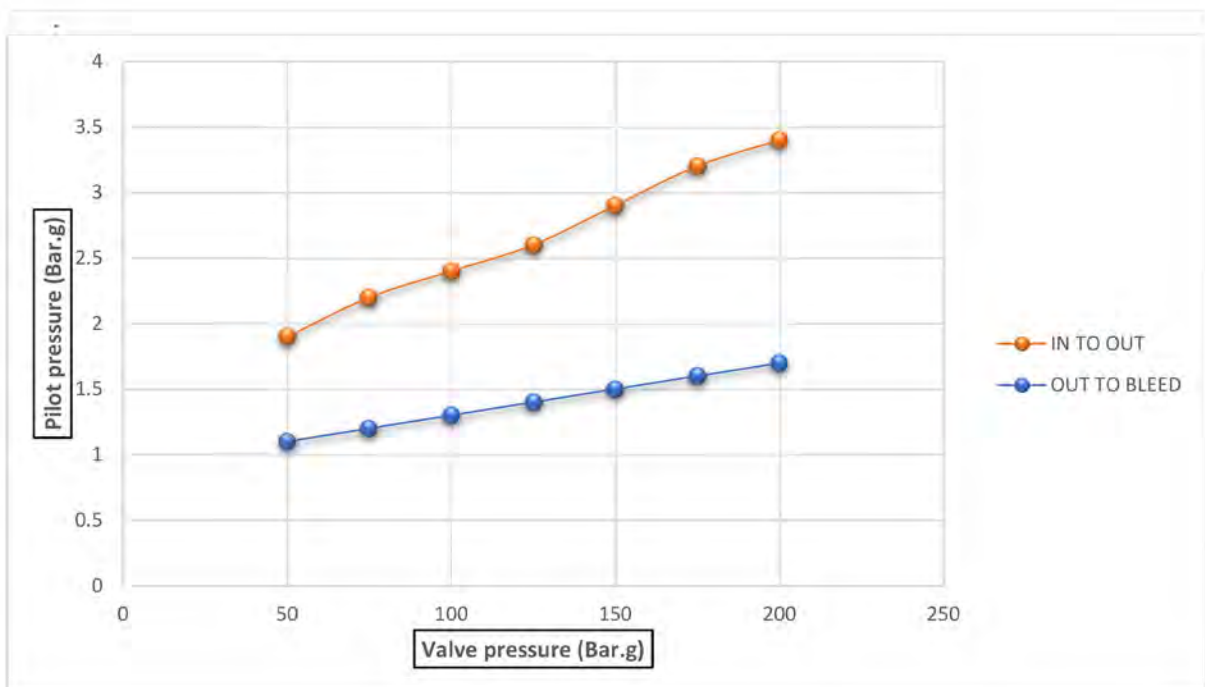

Note: Customised models and materials are available based on requirements.
 Above data are only for reference purpose and subject to change without any prior notice due to constant efforts on product improvement.



CONTACT US:



PETRONASH ENGINEERING SERVICES PVT LTD

F- 46 & 47, Bible College Road, 8th Main Road, 3rd Cross,
SIPCOT Industrial Park, Irungattukottai,
Sriperumbudur - 602 105, India



+91-44-66142800



irksales@petronash.com



+91-44-66142828



www.petronashengineering.com

